

ACUFLEX 400S/400D



NEW!

Specifications

Machine specifications			400S	400D
Left spindle slide	Spindle dia	mm [inch]	φ120 [φ4.71](*φ100 [φ3.9])	φ120 [φ4.71](*φ100 [φ3.9])
	Spindle nose		A2-8(*A2-6)	A2-8(*A2-6)
	Spindle bore	mm [inch]	φ76 [φ2.99](*φ42 [φ1.65])	φ76 [φ2.99](*φ42 [φ1.65])
	Spindle speed	min ⁻¹	5000(*6000)	5000(*6000)
	Spindle motor	kw [hp]	15/18.5 [20.1/24.8](Low Speed Motor Winding) 22/25 [29.5/33.5](High Speed Motor Winding)	15/18.5 [20.1/24.8](Low Speed Motor Winding) 22/25 [29.5/33.5](High Speed Motor Winding)
	Chuck size	inch	12,10 [0.47,0.39]	12,10 [0.47,0.39]
	Bar work size	mm [inch]	φ65 [φ2.56](*φ30 [φ1.18])	φ65 [φ2.56](*φ30 [φ1.18])
Right spindle slide	Spindle Min. indexing	degree	0.001	0.001
	Spindle dia	mm [inch]	φ100 [φ3.9]	φ100 [φ3.9]
	Spindle nose		A2-6	A2-6
	Spindle bore	mm [inch]	φ42 [φ1.65]	φ42 [φ1.65]
	Spindle speed	min ⁻¹	6000	6000
	Spindle motor	kw [hp]	15/18.5[20.1/24.8]	15/18.5[20.1/24.8]
	Chuck size	inch	10,8 [0.39,0.31]	10,8 [0.39,0.31]
Tail stock	Bar work size	mm [inch]	φ30 [φ1.18]	φ30 [φ1.18]
	Spindle Min. indexing	degree	0.001	0.001
Turret slide	Center built-in type		MT,4	MT,4
	Number of tool stations		12(*24)	12(*24)
	Turret mechanism		Three piece coupling	Three piece coupling
	Turret mount size		BMT 55(*45, 60)	BMT 55(*45, 60)
Slide type	Spindle speed for live tool	min ⁻¹	4000(*6000)	4000(*6000)
	Spindle motor for live tool	kw [hp]	4.5[6.0]	4.5[6.0]
Slide stroke	X-axis		Boxway	Boxway
	Y-axis		Boxway	Boxway
	Z-axis		Roller guide	Roller guide
	B-axis		Roller guide	Roller guide
Rapid traverse	X-axis(Upper slide)	mm [inch]	295 [11.61]	295 [11.61]
	X-axis(Lower slide)	mm [inch]	-	230 [9.06]
	Y-axis	mm [inch]	±50 [1.97]	±50 [1.97]
	Z-axis	mm [inch]	886 [34.88](★800 [31.5])	886 [34.88](★800 [31.5])
Feed motor	B-axis	mm [inch]	830 [32.68]	830 [32.68]
	X-axis	m/min	24	24
	Y-axis	m/min	12	12
	Z-axis	m/min	38	38
Footprint	B-axis	m/min	36	36
	X-axis	kw [hp]	3.0 [4.0]	3.0 [4.0]
	Ys-axis	kw [hp]	2.5 [3.4]	2.5 [3.4]
	Z-axis	kw [hp]	3.0 [4.0]	3.0 [4.0]
Weight	B-axis	kw [hp]	3.0 [4.0]	3.0 [4.0]
	Side exit: 4330x2400 [14'2" x 7'10"]	mm [feet,inch]		Side exit: 4760x2950 [15'7" x 9'8"]
CNC control	Rear exit: 3230x3090 [10'7" x 10'2"]	mm [feet,inch]		
	Height	mm [feet,inch]	2130 [6'12"]	2410 [7'11"]
Max. Part size	Weight	kg [lb.]	6500 [14330]	13000 [28660]
	CNC control		FANUC 0i-TF Plus	FANUC 0i-TF Plus
Max. Part size	Left	Upper turret	mm [inch]	φ460 [18.11]
		Lower turret	mm [inch]	-
	Right		mm [inch]	φ460 [18.11]

*Option
★ Long neck turret

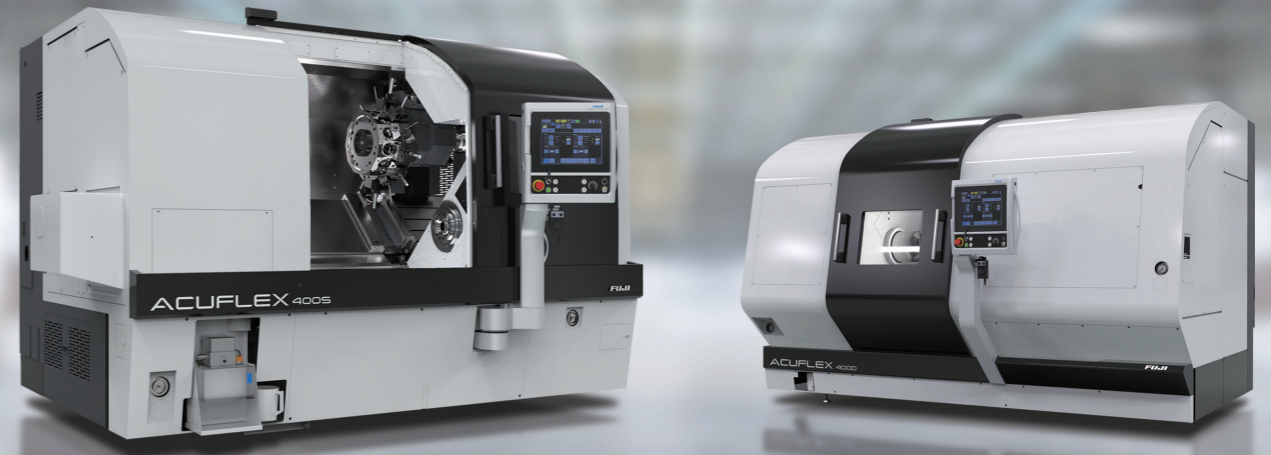

ACUFLEX 400S/400D

Multi Task CNC Lathe ACUFLEX series

Slide-ways designed to maintain exceptional rigidity , speed and accuracy.

World class work piece envelope design with high rigidity spindles.

BMT Style Live Tool Holders from various manufactures can be attached.

*Patent pending

Machine Overview

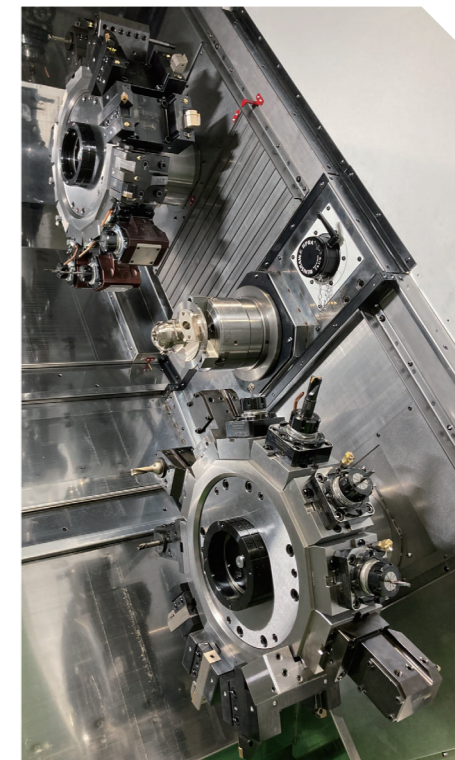
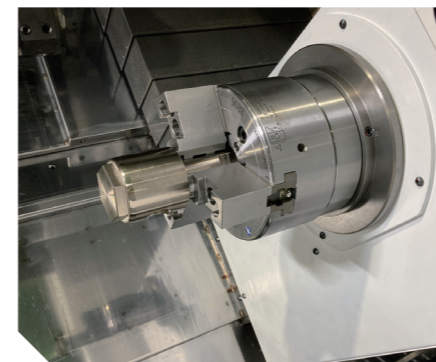
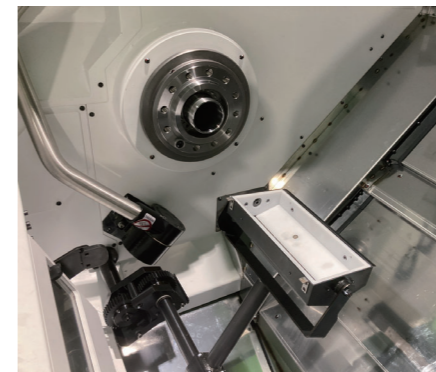
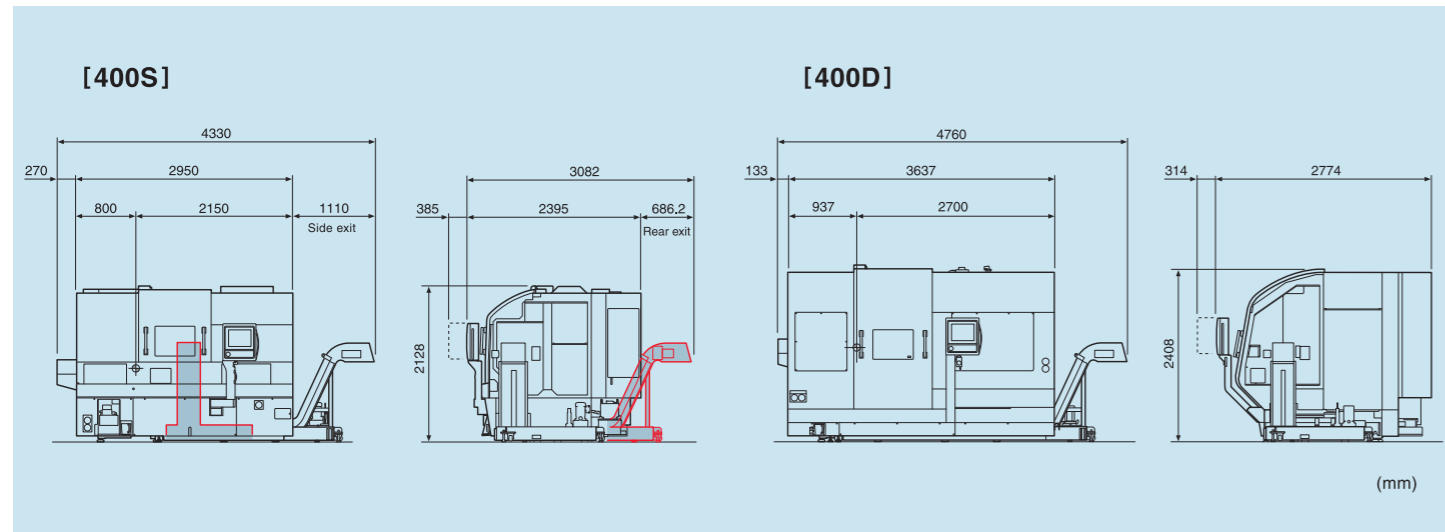

FUJI CORPORATION

Machine Tools Div. HQ/Plant
Address : 480 Tojiri, Hasama-cho, Toyota, Aichi 470-0452 Japan
Phone : +81(565)76-5485 Fax: +81(565) 76-5704

■ Specifications are subject to change without notice.
■ The photos include options.
■ The mentioned data on this catalog is actual value, but not a performance guarantee.

202308_ACUFLEX_II_A3_E_00

NEW!

ACUFLEX 400S/400D

Multi Task CNC Lathe

World Class Work Piece Envelope Design

On the left spindle, it's possible to install a 12-inch chuck, taking advantage of the spacious interior of the machine to accommodate sizable workpieces due to the generous swing design.

Swing over bed: $\phi 790$

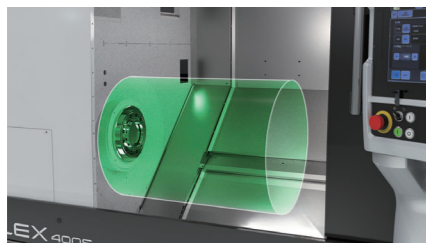

Selectable turrets

You have the choice between two options: a highly rigid short neck or a long neck design that offers flexibility for right spindle tooling. Additionally, you can choose between a 12-station or 24-station configuration.

short neck turret

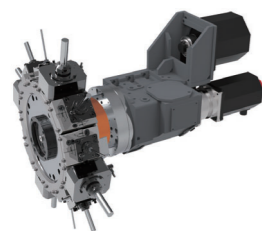

long neck turret

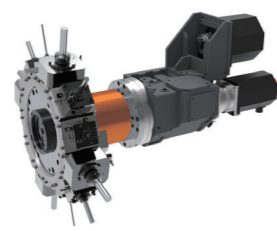

Selecting a chip conveyor

You can choose the chip conveyor's discharge direction, either from the right side or the rear, based on the nature of the work and the available space in the factory.

rear exit

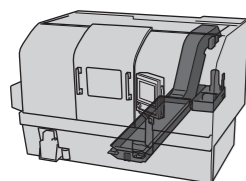

*Only 400S is supported

side exit

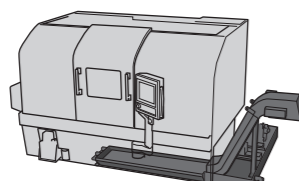

*Both 400S and 400D can be supported

High rigidity column

Employing a linear guide featuring a broad mounting pitch accomplishes optimal rigidity and speed for the Z-axis slide. Box way slides are implemented for the XY axis positioned closer to the machining point, facilitating robust cutting capabilities. The right spindle is capable of performing machining operations at a level equivalent to that of the left spindle.

400S (single turret)

400D (double turrets)

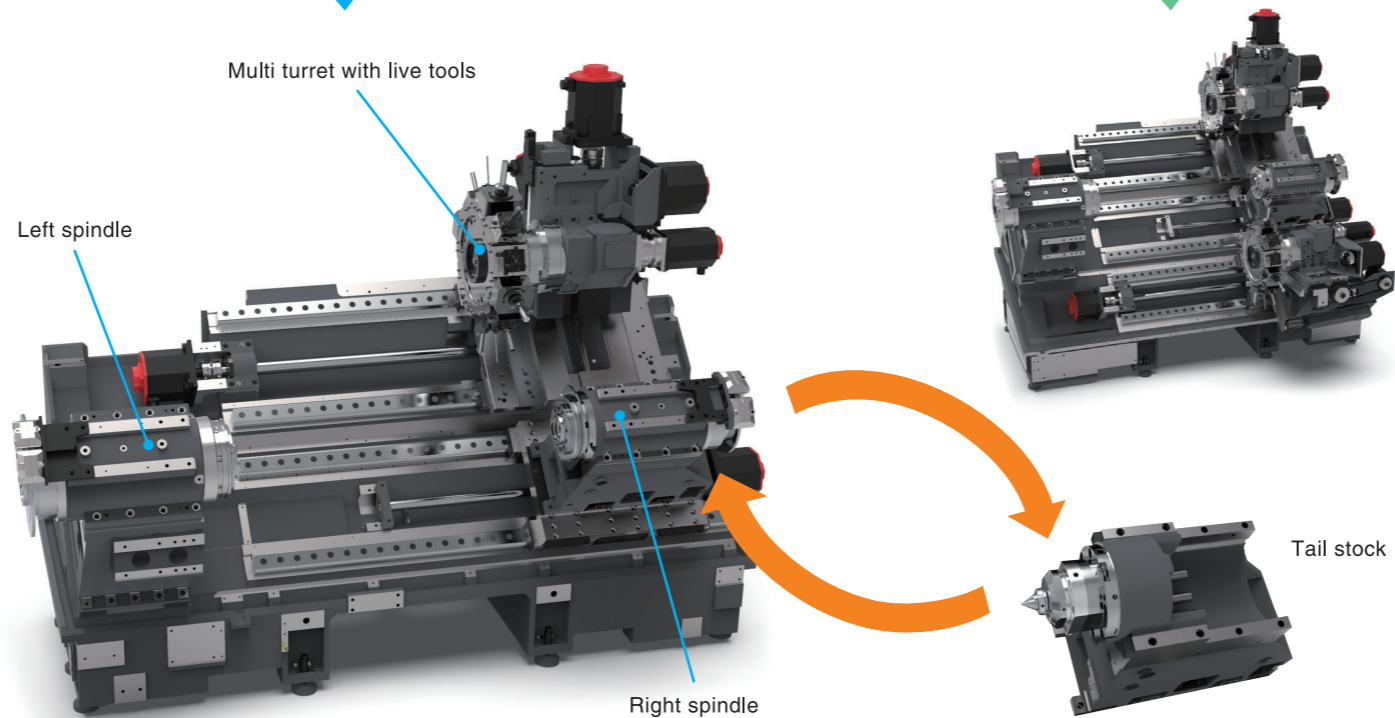

You can choose either a right spindle capable of accommodating a 10-inch chuck and accommodating a tail stock, based on the specific machining requirements.

Live tool

Commercially available BMTs are used. BMT45, BMT55 and BMT60 can be used.

Live tool specifications

Max. clamping tool dia.	ER32 Max. $\phi 22$ OP ER40 Max. $\phi 30$ CAPTO C4 Boring bar $\phi 40$ Square bite $\square 25$
Number of station	12
Spindle speed	4000min ⁻¹ OP 6000min ⁻¹
Spindle motor	4.5kw 22Nm

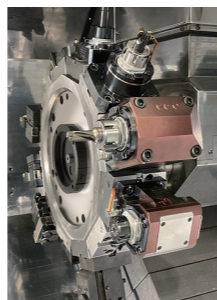

Anti-vibration Steady Rest Option

Chattering is minimized and stable machining of shaft workpiece is achieved with multiple types of steady rest option solutions.

400S

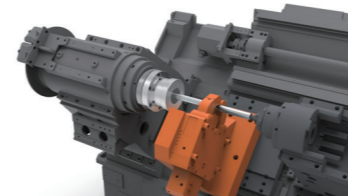

*Manual driving or automatic steady rest options can be selected

400D

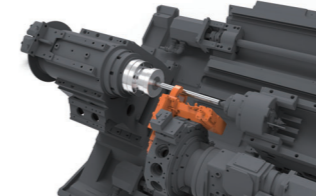

*An Optional Steady rest that can be directly attached to the lower turret is also available.

Parts catcher (400S)

The parts catcher accepts the finished workpieces within the machine and ejects them externally. You can opt for either a conveyor or a box as the unloading method.

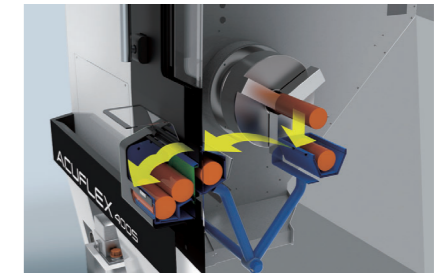

Parts robot (400D)

The parts catcher robot captures the finished workpiece within the machine and then expels them externally using the conveyor.

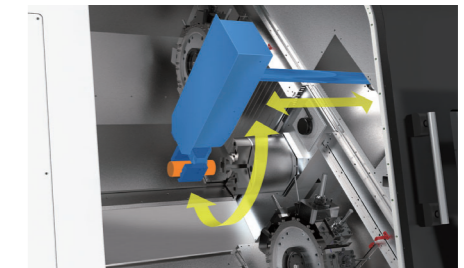

Bar feeder

Cutting bars is possible by attaching a bar feeder that corresponds to the workpiece's length and diameter.



*A FUJI Gantry Robot can be equipped as an option.

Reducing loads on operators

The door is bi-directional, allowing for opening and closing to both the right and left sides. The door open/close assist function helps to alleviate the operator's workload.

